

Forked Chain Plastic Scraper

Entecom Forked Chain Link & Plastic Scraper design

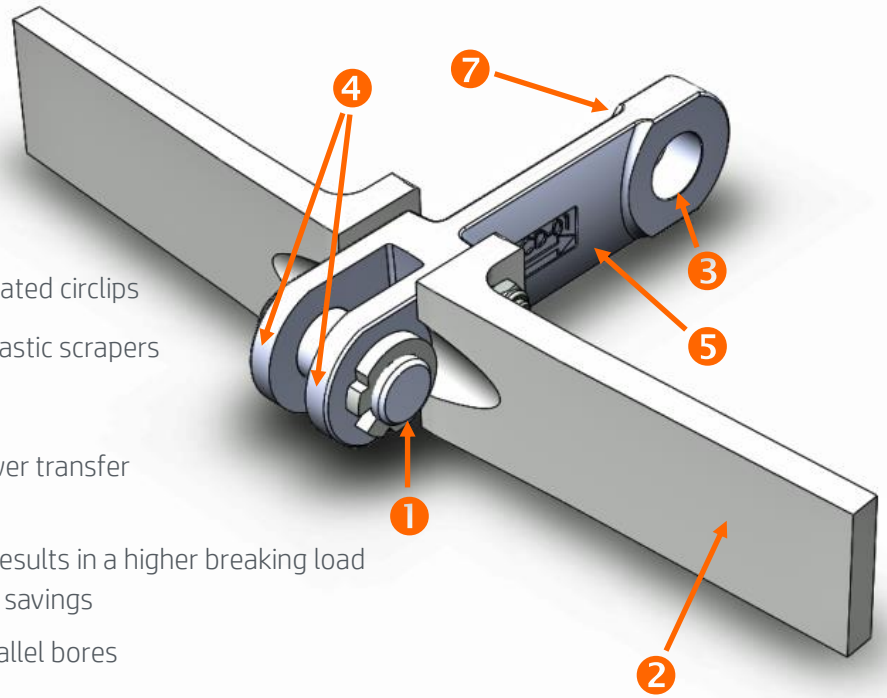

- 1 hardened pins with strong & zinc plated circlips
- 2 compatible, thicker and stronger plastic scrapers
- 3 deburred bores at exact pitch
- 4 parallel milled fork for uniform power transfer to the sprocket wheel
- 5 rounded body & minimized stamp results in a higher breaking load with even lower weight and energy savings
- 6 cnc machining for exact pitch & parallel bores
- 7 bigger tail radius improves lateral strength
- 8 constantly improved design based on field experience in conveyor systems
- 9 forged in cnc molds, sandblasted and deburred
- 10 improved heat treatment for extended lifetime and maximized strength

